

FRONTIER

Series II - F230



The ART of Dispensing

Frontier Series II offers a unique package that combines performance, reliability and options. The range includes single and dual configurations. Big, bold displays, a new and more accurate meter, and a great exterior image make this range a preferred choice.

Frontier Series II line of high hose island-oriented models are an excellent choice for high throughput sites. It delivers a timeless image, high quality performance, security and reliability helping your site differentiate from the rest.

Frontier Series II - F230

Value Drivers

Accuracy

- > Gilbarco HD Meter with eCalibration
- > Minimal Pulse Resolution for Higher Accuracy
- > 2-Stage Valve for Accurate Delivery in < 1 Litre Transactions
- > Accuracy in High Throughput Environments



Security

- > Theft Protection through Personalized Padlocks
- > Tamper-Resistant Electronics with Proprietary Interface Protocol
- > Interactive Electronics – No Pulse, No Flow System



Durability

- > High Visibility; Uniform Brightness 24hrs a Day
- > Self-Diagnostic Power Supply Safeguards Motor at < 180V
- > Surface Protection for Longer Image Life



Extended Warranty Program

Gilbarco warrants the product against defects in materials and workmanship. Enquire with local sales representative for extended warranty program.

Features & Options

Hydraulics		Electronics	
Pumping Unit	Global Pumping Unit – OIML approved and integrated air separation	Calculator	Electronic Register enabled with ARM processor and proprietary protocol
Motor	Rugged 1HP motor – 1 Phase, 220V / 3 Phase, 380V	Display	LED-lit superior backlight and contrast; 40mm Sale & Volume character height; 25mm character height for PPU display
Meter	Global Gilbarco Meter with eCalibration feature	Keypad	16 Key alphanumeric with self-enabled display
		Communication	GVR 2-wire communication protocol
Mechanical		Options	
Valves	1 Phase, 230V, 2-stage Solenoid Valve for accurate low volumes	Panels	Custom color side sheathing and lower door
Hydraulics Cabinet Door	Large size, coated, galvanized panel for custom branding; Width: 636mm, Height: 1136mm		
Hose Management	High Hose orientation with hose hanger on lower panel extends hose life		
Elevation	High Hose, 2.3 meters		
Dimensions	Product: Width 790 x Depth 540 x Height 2348 Packaging: Width 1070 x Depth 630 x Height 2450		

Refer to the warranty policy at the time of order confirmation.

Technical Specifications & Foundation Layout

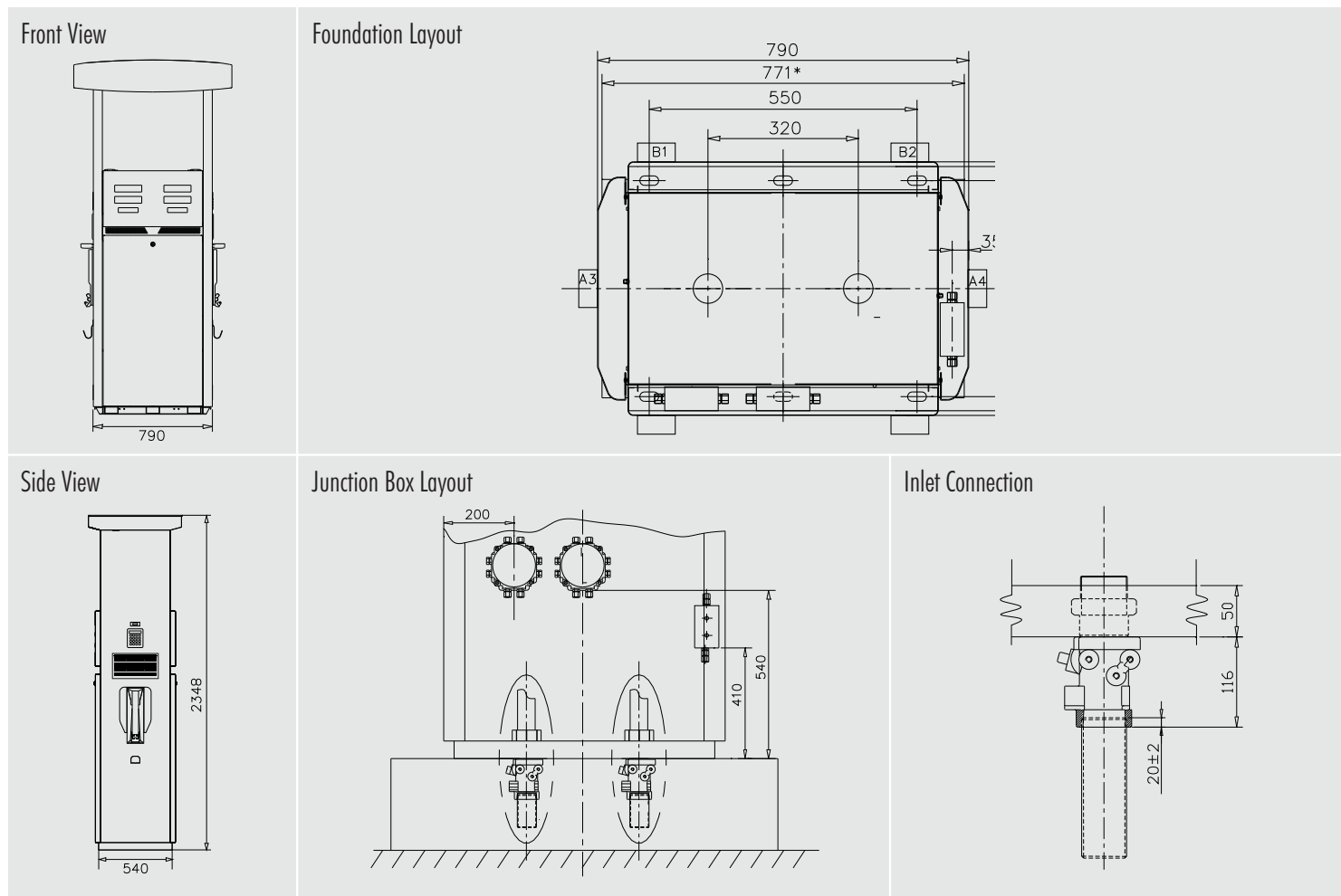

All dimensions above are in mm.

Single & Double-Sided Dispenser Configuration

Models	Suction Type	Pressure Type	Description	No. of Sides	Product Inlets	Dispensed Grades	Hoses Per Unit	Meters	Activation Type
F230-1	S	D	1-Grade, 1 Hose	2	1	1	1	1	Auto
F230-2	S	D	1-Grade, 2 Hose	2	1	1	2	2	Auto
F230-3	S	D	2-Grade, 2 Hose	2	2	2	2	2	Auto

Technical & Environmental Specifications

Flow Rates	Meter Accuracy	Ambient Temperature Range	Relative Humidity
Standard Flow – 10 GPM (30-40 LPM)	+/- 0.3% of measured volume per OIML R117/118	-20 °C to 55 °C	95%
High Flow – 18-22 GPM (70-80 LPM)			

Product Approvals

Full Product Approval:
ATEX & OIML R117/118
approved with Tulip electronics

Meter:
Gilbarco V+ meter,
OIML R117/118 approved

Pump:
Gilbarco GPU,
OIML R117/118 approved

Junction Box & Pulser Box:
Ex d IIB T5 Flameproof

Manufacturing Approvals
ISO 9001:2008

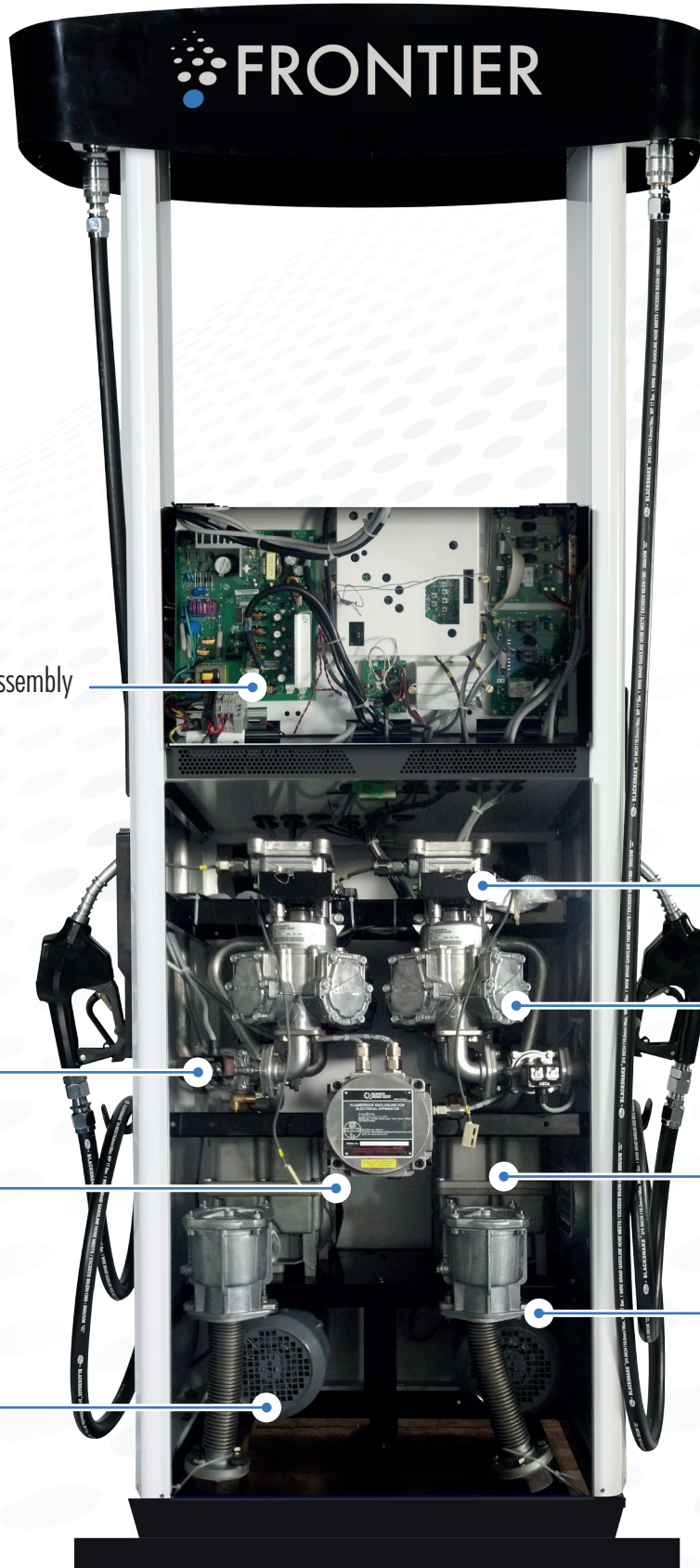

Protective Panel
exclusive to GVR;
increases electrical
safety multi-fold

Electronic Board Assembly

Pulser/Encoder

Meter

Valve

Pumping Unit

Jbox

Inlet Filter

Motor