FRONTIER ADBLUE®

FRONTIER ADBLUE® DISPENSERS ADAPTED TO FIT YOUR NEEDS



Keeping the World Moving



Why Frontier AdBlue®?

Available for either cars or trucks, or both - Ensuring our dedication and demonstrating our commitment to environmentally friendly transportation.

Reliable and Durable

The Frontier AdBlue® dispenser is a cost-effective solution that offers a quality construction with a reliable and robust structure for optimum strength. Powder coated, galvanised steel metal panels protect the dispenser against weather and scratches. We use best in class components across all of the Gilbarco Veeder-Root dispenser range and Elaflex hoses and nozzles to ensure durability of our products.

Flexible

The Frontier AdBlue® dispenser offers complete flexibility with different flow rates and 1-4 hose configuration. The Frontier AdBlue® dispenser is compatible with Fleet Management systems.

Secure and Easy to Use

Gilbarco Veeder-Root's Frontier AdBlue® dispenser uses secure and proprietary interface and for additional security. Our AdBlue® dispenser is available with an Integrated Heating System. The most efficient and future proof heating system consists of the patented hose heating system, temperature sensor and heater inside the hydraulic. It is designed for handling with ease of maintenance which in-turn lowers your total cost of ownership.

Value for Money

The Frontier AdBlue® uses a secure, proprietary interface for additional security. With corrosion proof, electromagnetic flow meter, which is highly advanced and provides accurate measurement without any moving parts or drift, providing robust operation to enable damage free fuelling and eliminating product losses.

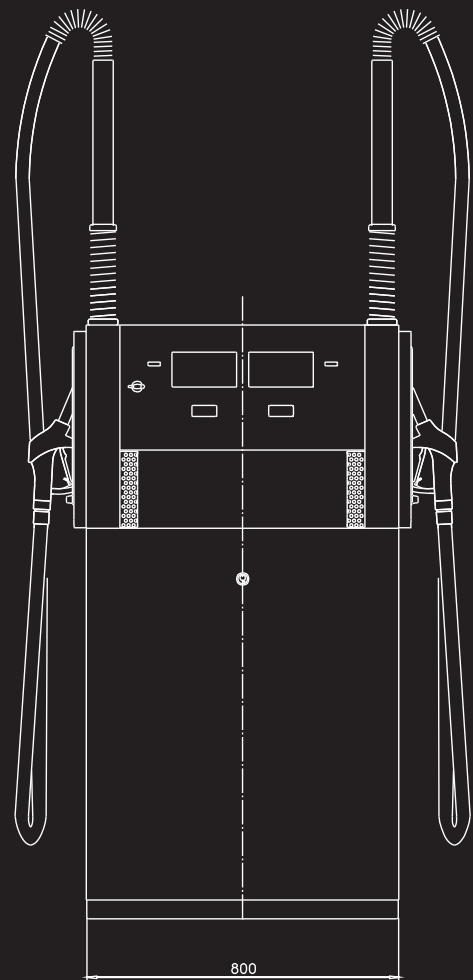

ADBLUE® Dispensing Solutions

The new Frontier AdBlue® Dispensers for cars and trucks, with ATEX and MID approvals. An addition to our flagship SK700-II platforms.

- > Available for either cars or trucks, or both
- > Can be Standalone AdBlue® Dispenser or Combi dispenser with Diesel or Integrated with above ground tank 1,100; 4,000; 5,000; 7,500 or 10,000 litre
- > Models from 1-hose/1-grade to 4-hose/2-grade with up to 4 displays
- > High performance flow meter without drift and without moving parts
- > Patented Hose Heating System allows operating temperature down to -25°C
- > Available with ATEX and MID approvals



Configurations and Combinations

Gilbarco Veeder-Root's Frontier AdBlue® pumps are available in island orientated, single or double sided configuration, or in combination with diesel, with different options for nozzle protection and heaters suited to different climatic conditions. They're also available integrated with above ground tanks.

Standard features	Options	Technical specifications
Single grade or two grades	High Flow (70 lpm) & Ultra High Flow (120 lpm)	Motor 3 Phase Supply 430V +/- 10%, 50 Hz +/- 2Hz
Max. 2 simultaneous fuelling positions	40/70 speed select button	Positive displacement meter with Electronic Calibration for Diesel and electromagnetic flow meter for AdBlue®
AdBlue®, Diesel, Biodiesel	Stainless steel front panels & hydraulic cabinet	15 minute display hold in case of power failure
Up to 4 hoses & 4 displays	Special Colours	Communication Protocols: Currently supports IFSF, 2-Wire, Pumalan, ER3, ATCL, Multiwire (Pulse)
Stainless Steel Hose mast	Base frame / leakage plate	Environmental: -25 °C to +45 °C
Combi main LCD displays with LED & with dedicated PPU's	Enhanced Corrosion Protection	Accuracy +/- 0.5%
Sandpiper II (E101) Electronics	Explosion Proof Junction Box	ATEX, MID, CE Approvals
Gilbarco 2 wire communication protocol	10 button Cash & Volume Preset Keypad	
Elaflex Hanging Hardware	Ecometer for Diesel	
Electromagnetic flow meter for AdBlue® and positive displacement meter with e-calibration	Automatic Temperature Compensation for Diesel	
Gilbarco Pumping Unit for Diesel	Nozzle Boot Locks	
Powder Coated Galvanised Steel	7 digit Electro Mechanical non-resettable totalizers	
RAL Grey colour for side panels & head	For use with STP for Diesel	
Hydraulic panels available in all standard colours	Volume only display	

Technical Specifications

Technical Specifications & Standard Features

Hydraulics	Electromagnetic flow meter for AdBlue® Stainless steel internal piping and connections Non return valve and filter AdBlue® delivery – Pressure Flow rate from 2L to 40L per minute for cars and trucks Power supply: 230V (+10%-15%), 50Hz ± 2Hz
Electronics	Gilbarco Calculator LCD display (backlit) Interface: 2-wire, IFSF-LON, ATCL, PUMA LAN, Multiwire (Pulse), ER3
Mechanical	Electronics – Stainless steel valves Housing – Powder coated steel Hose Reach 3,70m Hose management – Hose mast as standard Nozzles – ZVA
Options	Elaflex swivel Breakaway coupling Electromechanical totalizers Nozzle adaptor AdBlue® preset Stainless steel cladding Stainless steel installation kit Enhanced corrosion protection Frontier EU standard options

Versions	Base (not heated)	Heated
Hydraulic cabinet heater	not included	included
Hose heater	not included	Hose heating system included
Power consumption heating system	not included	250 Watt (per AdBlue® hose)
Min. operating temperature	down to -10°C	down to -25°C
AdBlue® breakaway	optional	optional
Nozzle cover	optional	optional (needs to be selected with breakaway option)
Certifications	MID & Atex (Optional)	MID & Atex (Optional)

Dimensions: Height: 2330mm, Width:800 mm, Depth: 560mm.

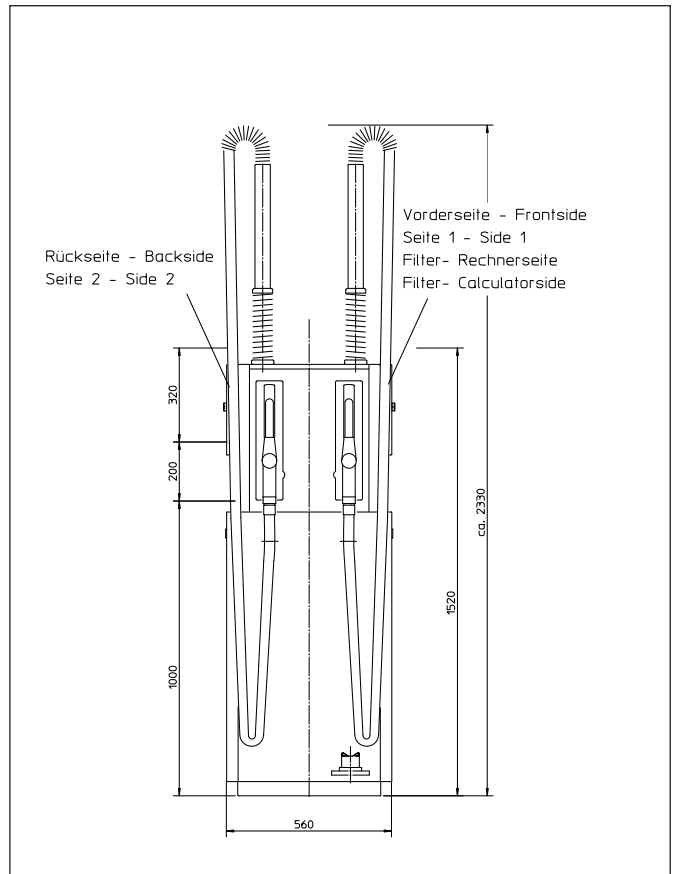
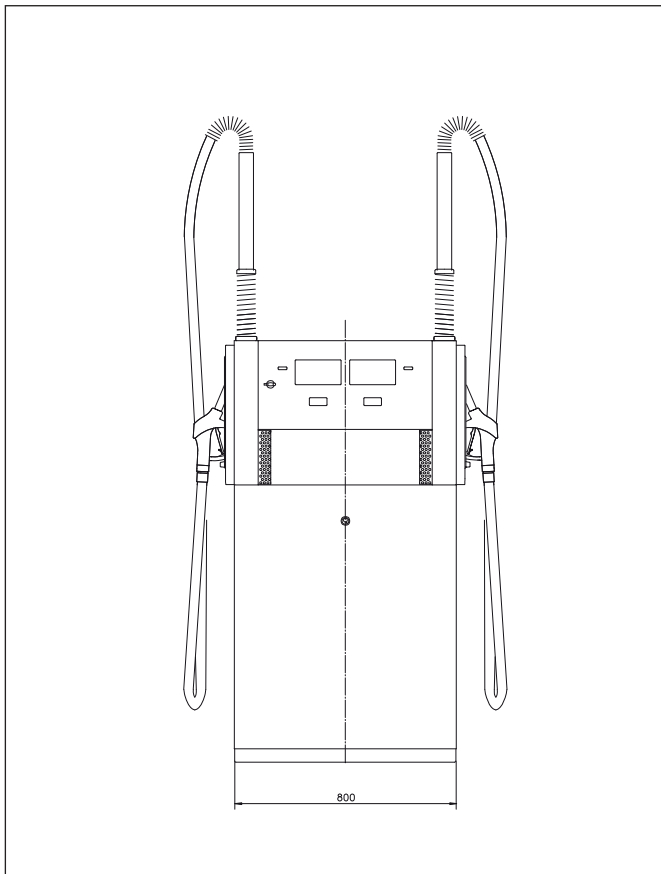

The full SK700-II AdBlue® Range

Our Comprehensive Range of AdBlue® Dispensers for Cars and Trucks demonstrate Gilbarco Veeder-Root's commitment to introducing environmentally friendly products at the forecourt.



SK700-II AdBlue® Standalone

Compact and robust

- > Lane orientation
- > Easy hose handling
- > Electromagnetic Flow Meter
- > 1 to 4 nozzles - truck and car
- > ATEX version available
- > Small footprint



SK700-II AdBlue® Integrated

Plug and play

- > SK700-II AdBlue® Standalone integrated with above ground storage
- > Single or Double sided
- > Capacity: 1,100L; 4,000L; 7,500L; 5,000L; and 10,000L
- > Satellite installation as an option

SK700-II AdBlue® Combi

Flexible and Modular – Multi-grade dispensing solution for cars and trucks

- > Standalone, Integrated or Combi
- > Lane orientation
- > AdBlue® with up to four petrol/diesel grades
- > ATEX version available
- > Easy hose handling
- > Electromagnetic Flow Meter



Why AdBlue® Dispensers?

Our AdBlue® range of dispensers for Cars and/or Trucks demonstrates Gilbarco Veeder-Root's commitment to introducing environmentally friendly products at the forecourt.

Tighter European emission limits for vehicles have strongly increased the demand for AdBlue® filling stations. However, AdBlue® can literally destroy filling equipment, as it is highly corrosive, temperature sensitive and crystallises in contact with air. Minor impurities can easily damage the expensive truck catalytic system.

The Gilbarco Veeder-Root's Frontier AdBlue® dispensers feature the corrosion proof, electromagnetic flow meter, which is highly advanced in the industry and provides accurate measurement without any moving parts or drift, providing robust and durable operation, enables damage free fuelling and eliminates product losses.

AdBlue® freezes at -11°C and crystalizes upon contact with air, the electromagnetic flow meter has no moving parts therefore remains unaffected by crystals, while pumps which use standard piston meters with moving parts can get blocked. Gilbarco Veeder-Root's AdBlue® dispensers are available with an integrated heating System. Our patented hose heating system eliminates the need for nozzle covers while still keeping the hose heated. The heating power will automatically adjust based on environment temperature minimizing heating cost while maintaining operating temperature. The nozzle cover is available when hose break away is installed in cold environments.

The Fail Safe AdBlue® Filling Solution

Fail Safe

The pressure delivery system avoids crystallisation and dispenser hydraulics are corrosion proof, while automatic heating prevents AdBlue® from freezing.

Versatile

Choose from Standalone, Combi or Integrated configurations to build the right solution for your forecourt.

Design Matters

The Frontier AdBlue® incorporates the highly advanced electromagnetic flow metering system. It has no moving parts and no drift to ensure it will not block and maximises uptime, while providing very accurate measurement eliminating product loss.

Proven

AdBlue® freezes at -11°C. SK700-II AdBlue® installations have continuously performed in countries like Finland at temperatures down to -40°C.

Gilbarco Veeder-Root Solutions

With a universal range, global reach, deep-rooted expertise and superior customer service, Gilbarco Veeder-Root is committed to building better business for its customers.

Pumps & Dispensers

Robust, reliable, accurate and secure technology

Our Pumps and Dispensers feature flexible, innovative and upgradable technology. They not only grow with your business, but also improve the forecourt experience for your end-users.

By focusing on the unique requirements of our customers, we deliver high quality and reliable solutions that are designed to support better business now and in the future.

Our range includes:

- > Multi-Product Dispensers
- > Single and Dual Dispensers
- > Alternative Fuels
- > Applause Europe (multimedia)
- > Submersible Turbine Pumps
- > Commercial Dispensers



Business Support

Protect assets and drive operational efficiency

Our Business Support solutions minimise downtime and disruption by providing the tools, services and technology necessary for our customers to get more from their businesses.

With an extensive reach throughout Europe, you can be assured that no matter where your business takes you, our comprehensive range of services will always be available.

Wetstock Management

Improve performance, uptime and security

Our comprehensive range of compliant and reliable Wetstock Management solutions offer you advanced engineering and a responsive service. Scalable and customisable, our tools provide control, security and data across networks of all sizes anywhere in the world.

Ultimately, our solutions enable you to stay compliant and in control.

Retail Solutions

Maximise profitability and minimise overheads

Our leading Point of Sale, Head and Back Office Systems and forecourt controllers create new business at the pump and enable deeper insights into stock, logistics and security.

Working alongside our wide range of products and services, our Retail Solutions are designed to work for you.

AdBlue® is a registered trademark of Verband Der Automobilindustrie (VDA).

Building Better Business

Tel: +971 4 560 7900
E-mail: salesmea@gilbarco.com
Visit us: www.gilbarco.com/mea

 **GILBARCO
VEEDER-ROOT**