

FRONTIER

Series I - F160

The **ART** of Dispensing

The new Frontier Series I offers functional and reliable high hose and low hose models in single and dual configurations. Models are available as a suction or pressure type, and use rugged Gilbarco Veeder-Root global components, making them dependable even in harsh field conditions. Series I is offered in Standard Flow-40LPM and High Flow-80LPM options.

Low throughput sites or cost efficient independent owners find Series I low hose model best suited for their needs. It offers excellent value on price, functionality and reliability.



Frontier Series I - F160

Value Drivers

Accuracy

- > Gilbarco HD Meter with eCalibration
- > Minimal Pulse Resolution for Higher Accuracy
- > 2-Stage Valve for Accurate Delivery in < 1 Litre Transactions
- > Accuracy in High Throughput Environments



Security

- > Theft Protection through Personalized Padlocks
- > Tamper-Resistant Electronics with Proprietary Interface Protocol
- > Interactive Electronics – No Pulse, No Flow System



Durability

- > High Visibility; Uniform Brightness 24hrs a Day
- > Self-Diagnostic Power Supply Safeguards Motor at < 180V



2 Year Warranty

Gilbarco warrants the product against defects in materials and workmanship for 2 years from the date of installation. (*Certain conditions apply. Installation required within 6 months from the date of the Gilbarco invoice. Installation details [equipment serial number, site name and site address] should be provided. Any installation that does not comply with the conditions will not be covered under warranty.*) Reference standard warranty terms and conditions at the time of order.

Features & Options

Hydraulics		Electronics	
Pumping Unit	Global Pumping Unit – OIML approved and integrated air separation	Calculator	Electronic Register enabled with ARM processor and proprietary protocol
Motor	Rugged 1HP motor – 1 Phase, 220V / 3 Phase, 380V	Display	LED-lit superior backlight and contrast; 25mm Sale & Volume character height; 25mm character height for PPU display
Meter	Global Gilbarco Meter with eCalibration feature	Keypad	16 Key alphanumeric with self-enabled display
Mechanical		Communication	GVR 2-wire communication protocol
Valves	1 Phase, 230V, 2-stage Solenoid Valve for accurate low volumes	Options	
Hydraulics Cabinet Door	Large size, coated, galvanized panel for custom branding; Width: 666mm, Height: 1136mm	Panels	Custom color side sheathing and lower door
Hose Management	Low Hose orientation with hose hanger on lower panel extends hose life		
Elevation	Low Hose, 1.6 meters		
Dimensions	Product: Width 790 x Depth 540 x Height 1650 Packaging: Width 1070 x Depth 630 x Height 1780		

Refer to the warranty policy at the time of order confirmation.

Technical Specifications & Foundation Layout

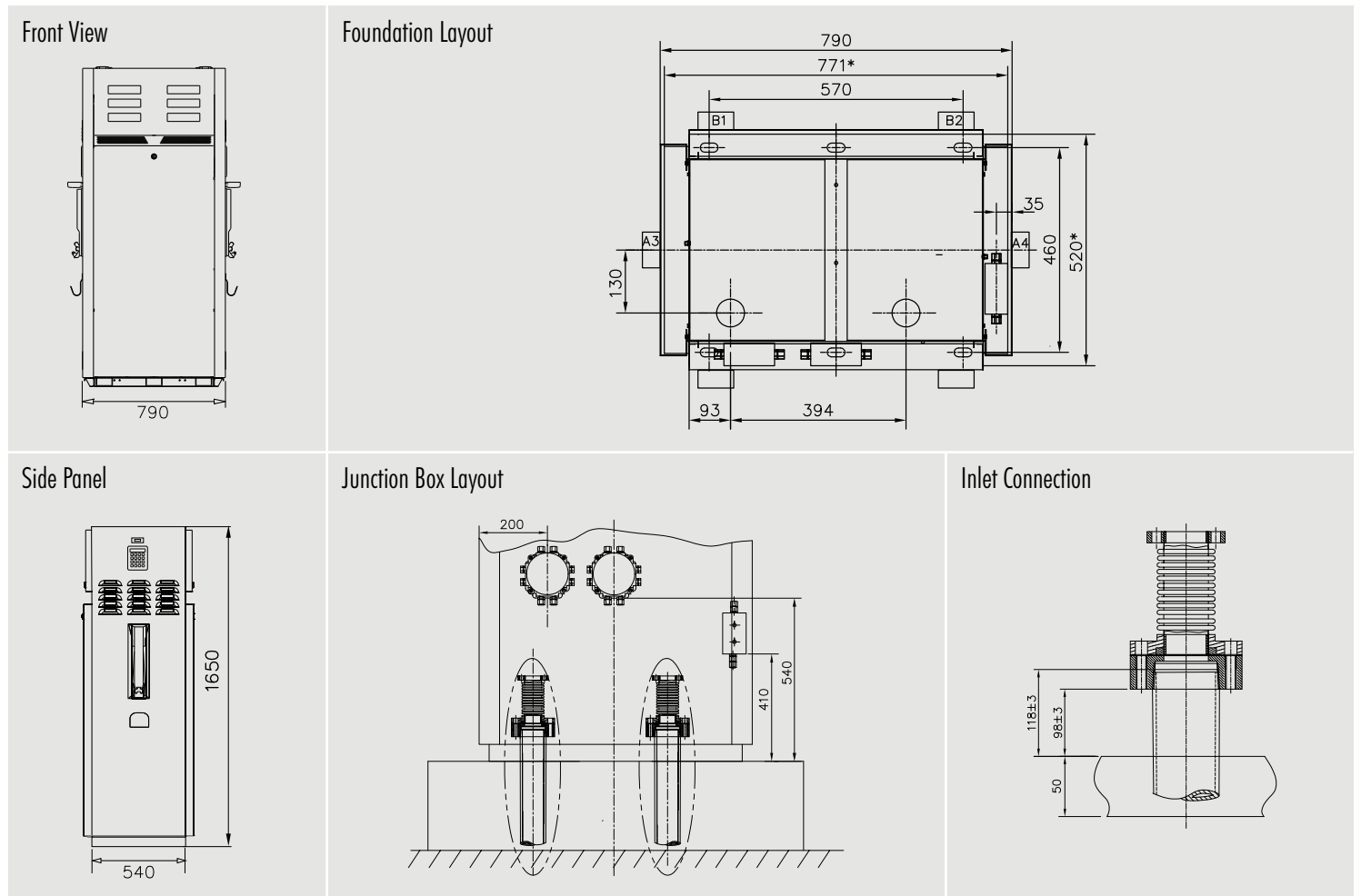

All dimensions above are in mm.

Single & Double-Sided Dispenser Configuration

Models	Suction Type	Pressure Type	Description	No. of Sides	Product Inlets	Dispensed Grades	Hoses Per Unit	Meters	Activation Type
F160-1	S	D	1-Grade, 1 Hose	2	1	1	1	1	Auto
F160-2	S	D	1-Grade, 2 Hose	2	1	1	2	2	Auto
F160-3	S	D	2-Grade, 2 Hose	2	2	2	2	2	Auto

Technical & Environmental Specifications

Flow Rates	Meter Accuracy	Ambient Temperature Range	Relative Humidity
Standard Flow — 10 GPM (30-40 LPM)	+/- 0.3% of measured volume per OIML R117/118	-20 °C to 55 °C	95%
High Flow — 18-22 GPM (70-80 LPM)			

Product Approvals

Full Product Approval:
ATEX & OIML R117/118
approved with Tulip electronics

Meter:
Gilbarco V+ meter,
OIML R117/118 approved

Pump:
Gilbarco GPU,
OIML R117/118 approved

Junction Box & Pulsar Box:
Ex d IIB T5 Flameproof

Manufacturing Approvals
ISO 9001:2015

