

SK700-II ADBLUE® STANDALONE

A compact and robust solution

- > Lane orientation
- > Easy hose handling
- > Electromagnetic flowmeter
- > 1 or 2 nozzles
- > Also available in ATEX version
- > Small footprint



Keeping the World Moving



 **GILBARCO
VEEDER-ROOT**

Product specifications

The compact design means that the SK700-II AdBlue® Standalone can be accommodated on any forecourt, with a unique design which allows for fool proof operation. The SK700-II AdBlue® is made from the highest quality stainless steel and specially coated materials to withstand corrosion and damage.

Technical Specifications & Standard Features		
Hydraulics	Electromagnetic Flowmeter Stainless steel internal piping and connections Non return valve and filter AdBlue® delivery – Pressure Flow rate 2L-40L/min. for cars and trucks Power supply: 230V (+10% -15%), 50Hz ± 2Hz	
Electronics	Gilbarco Calculator LCD display (backlit) Interface: 2-wire, IFSF-LON, ATCL, PUMA LAN	
Mechanical	Electronics – Stainless steel valves Housing – Powder coated steel AdBlue® hose reach 3,10m (without hose retraction = standard) 3,50m (with hose retraction = option) Hose management – Internal hose with retraction as standard Nozzles – ZVA	
Options	Elaflex swivel Break-away couplings Electromechanical totalisers Nozzle adaptor AdBlue® preset Stainless steel hose column Stainless steel installation kit Stainless steel cladding Enhanced corrosion protection SK700-II standard options	
Versions	Base (not heated)	Heated
Hydraulic cabinet heater	not included	Fuheat system
Hose column heater	not included	Hose with trace heater
Power consumption	-	700 watts
Min. operating temperature	down to -10°C	down to -25°C (optional down to -40°C)
AdBlue breakaway	Optional	Available up to -25°C
Nozzle cover	Optional	Optional
Certifications	MID & Atex (Optional)	MID & Atex (Optional)

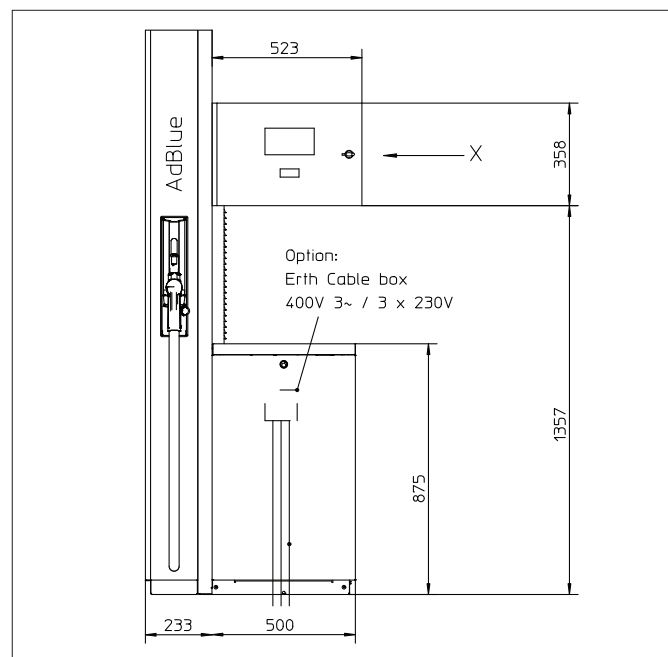
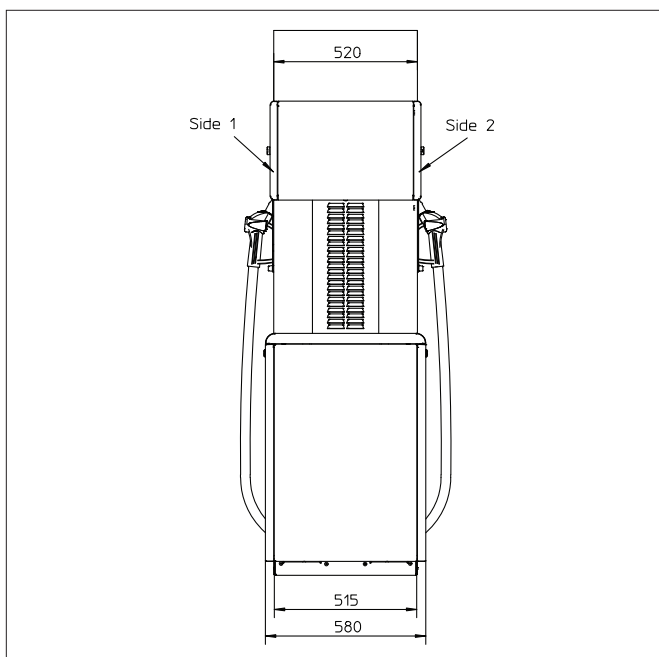

Adblue® is a registered trademark of Verband Der Automobilindustrie (VDA).

Keeping the World Moving

Tel: +44 (0) 1268 533090
E-mail: evenquiries@gilbarco.com
Visit us: www.gilbarco.com/eu

Follow us on:
LinkedIn: [gilbarco-veeder-root-europe](https://www.linkedin.com/company/gilbarco-veeder-root-europe)
Twitter: [gvr_europe](https://twitter.com/gvr_europe)

