

RJ DEF System

Quick Reference Guide

Manual No. 577014-111 • Rev A

Please refer to the Red Jacket DEF Pump Installation Manual (P/N 577014-062) for additional information.

Installing Impeller Cover

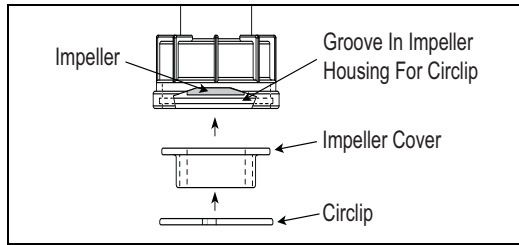

Installing Impeller Cover Retaining Circlip

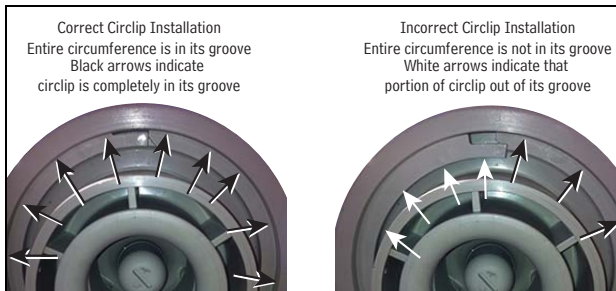

DEF Pump Bottom Positioning

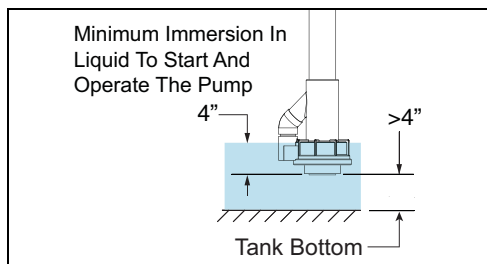

Installation Notes

1. Hand tighten the manifold's return line bonnet nut, then using a wrench, carefully tighten the bonnet nut an additional $\frac{1}{2}$ turn (see below). Counter this torque by placing a wrench around the collar bushing on the return pipe fitting. Thread sealant is not required on this thread.

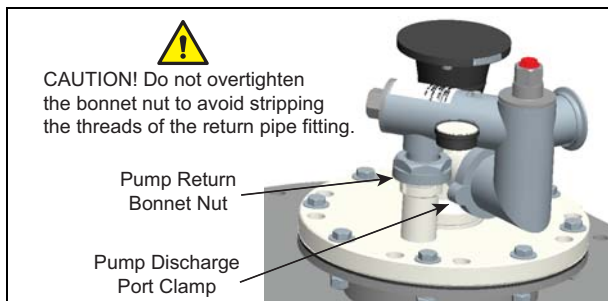

2. Visually inspect the discharge line connection for proper gasket position and clamp alignment then tighten the locking bolt on the clamp to 3 ft-lb (4 N•m) maximum (see below).

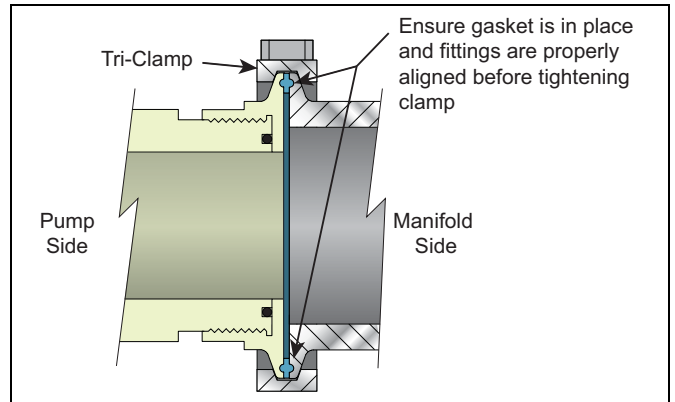

Determining Motor Rotation For Both 230V and 460V Applications



Warning: To avoid pump damage, the DEF pump must always be operated in the correct direction (ref. arrow indicator located on the pump flange).

To insure correct rotation a Phase Sequence Tester shall be used to determine proper rotation, prior to applying power to the RJ DEF Motor.

1. Using the Extech Model 480400 Phase Sequence Tester, connect the color coded test leads to the input jacks on the top of the Phase Sequence Tester making certain that the proper color coding is followed (L1 red to red; L2 yellow to yellow, L3 blue to blue).
2. After the wiring has been installed from the RJ Motor Starter to the sump area and BEFORE connecting the power wiring to the motor leads, turn off, tag, and lock out power to the RJ DEF pump.



Warning: Insure sump area does not contain any explosive gases!

3. Connect the three Phase Sequence Tester lead alligator clips to the three incoming RJ DEF motor power wires.
4. Apply power to the circuit (230 or 460 Vac) and note the reading on the Phase Sequence Tester. Proper pump rotation will be indicated by the counterclockwise rotation icon on the Phase Sequence Tester screen (see below).



5. If the rotation is incorrect, disconnect power, switch any two of the alligator clip connections and then re-apply power and confirm correct rotation.
6. Once the correct motor rotation is confirmed turn off, tag, and lock out power to the RJ DEF pump. Before removing the alligator

clips place a piece of tape around each wire end and mark the tape on each wire L1, L2 or L3 as appropriate.

7. Disconnect the Phase Sequence Tester from the incoming pump power wires. Connect the power conductor identified as L1 from the Phase Sequence Test (RED lead - L1) to the motor conductor #1 wire; connect the power conductor identified as L2 from the Phase Sequence Test (YELLOW lead - L2) to the motor con-

ductor #2; connect the power conductor identified as L3 from the Phase Sequence Test (BLUE lead - L3) to the motor conductor #3.

8. Reference the complete wiring schematics for both Low and High Voltages as provided below and on the cover of the RJ DEF Pump Motor J Box.

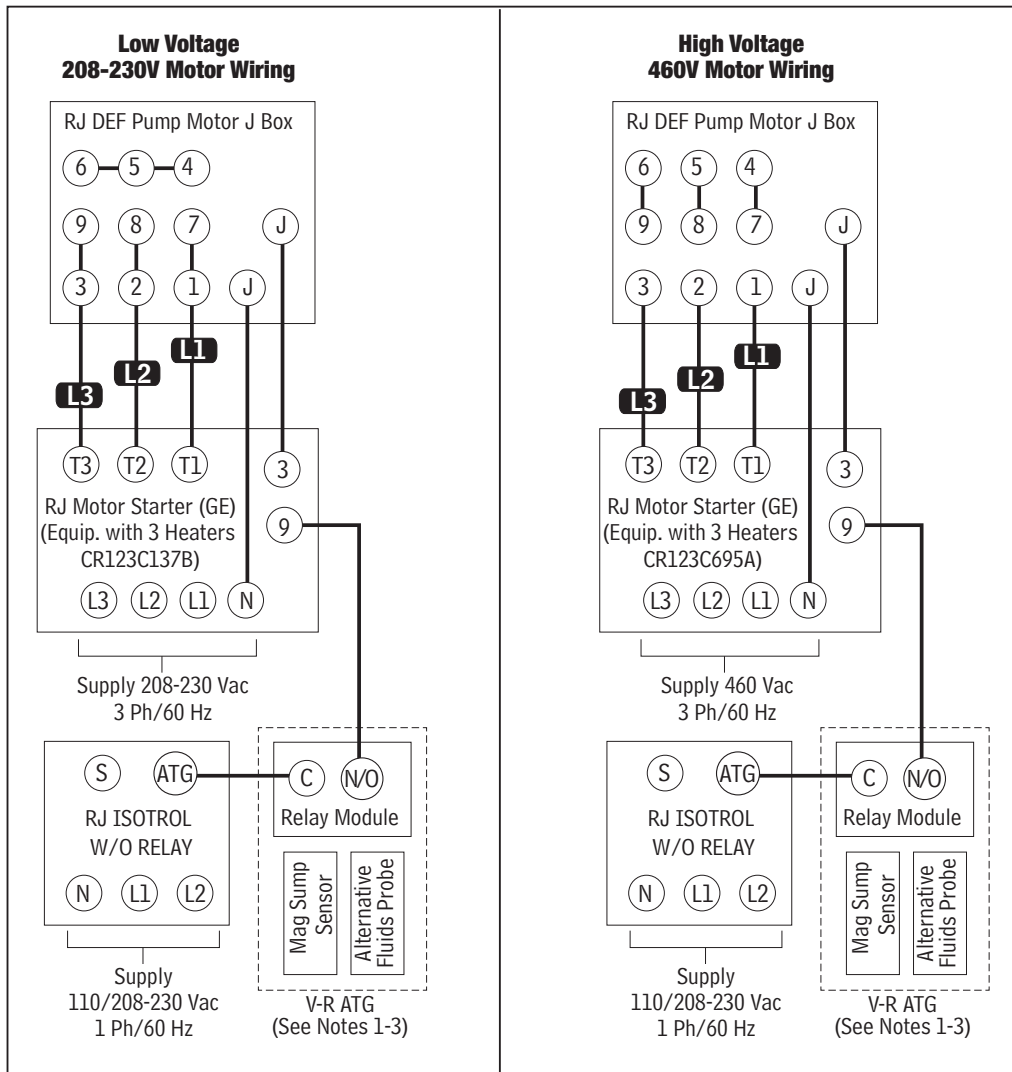

NOTES:

1. Alt. Fluids Probe to be wired into ATG and configured such that the low inventory alarm will cause the ATG relay to de-activate the RJ DEF pump. Reference 10 inches from tank bottom.
2. Mag Sump Sensor to be wired into ATG and configured such that the liquid alarm will cause the ATG to de-activate the RJ DEF Pump.
3. The ATG Relay to be wired to N/O connection, but the ATG is to be programmed to N/C.

ATG Setup for RJ DEF System

Pump Control Relay

Wire the relay to a N.O. connection in the ATG, but program the relay in the ATG to N.C.

Mag Sump Sensor

Program the Mag Sump Sensor to Warn at 6 inches and to Alarm at 15-20 inches.

Mag Probe

Set the Low level Alarm to 10 inches.

Output Relay

Program the output relay such that the RJ starter will interrupt power to the RJ DEF pump motor for the Mag Probe and Mag Sump sensor alarms and warnings.